

CHRONO 25 A

NF E 52081 - E 52082

DIN 15018 H1 B3 K3

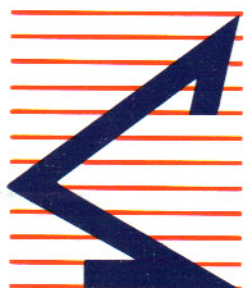

CADILLON

Cotes

Abmessungen

Dimensions

Dimensiones

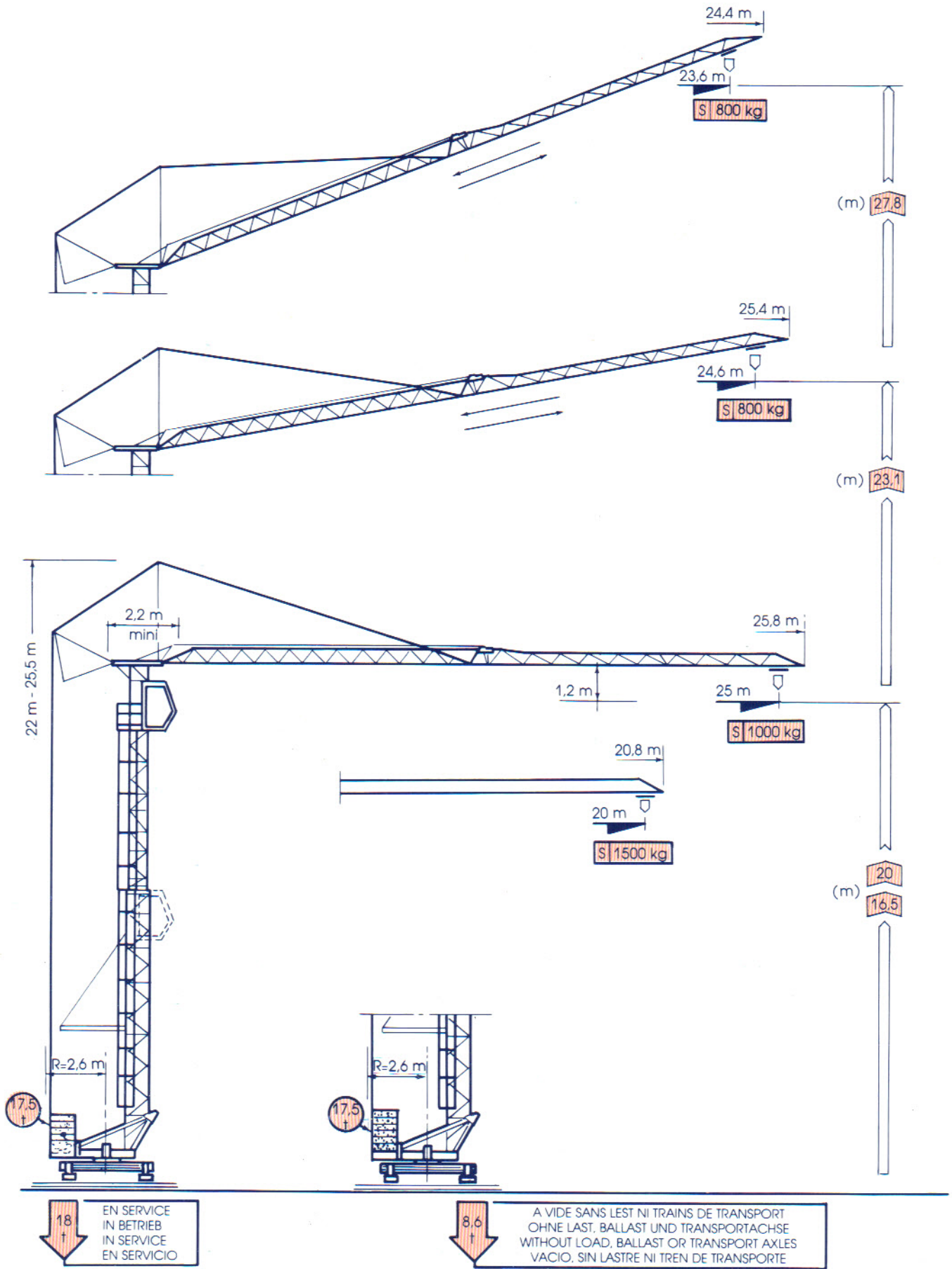

CHRONO 25 A

S		10.5	11	11.5	12	13	14	15	16	17	18	19	20	21	22	23	25 m
25 m		3000	2830	2670	2530	2280	2080	1900	1750	1630	1510	1410	1330	1250	1180	1110	1000
20 m				3000	2840	2560	2340	2140	1980	1830	1710	1600	1500				kg

Courbes de charges

Lastkurven

Load curves

Curvas de cargas

Versions sur chassis

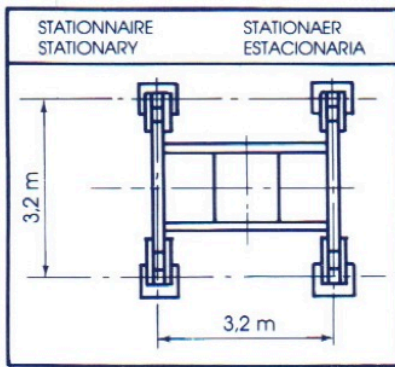

Unterwagen

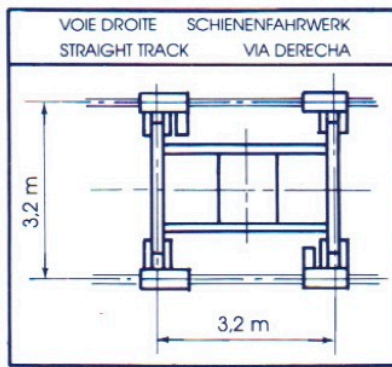

Undercarriage

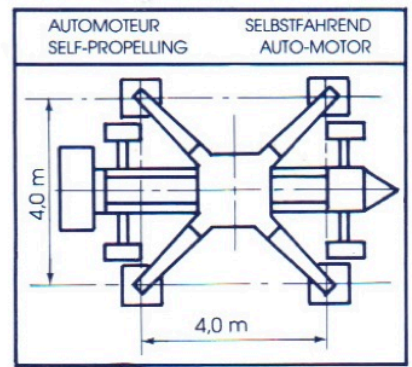

Chassis

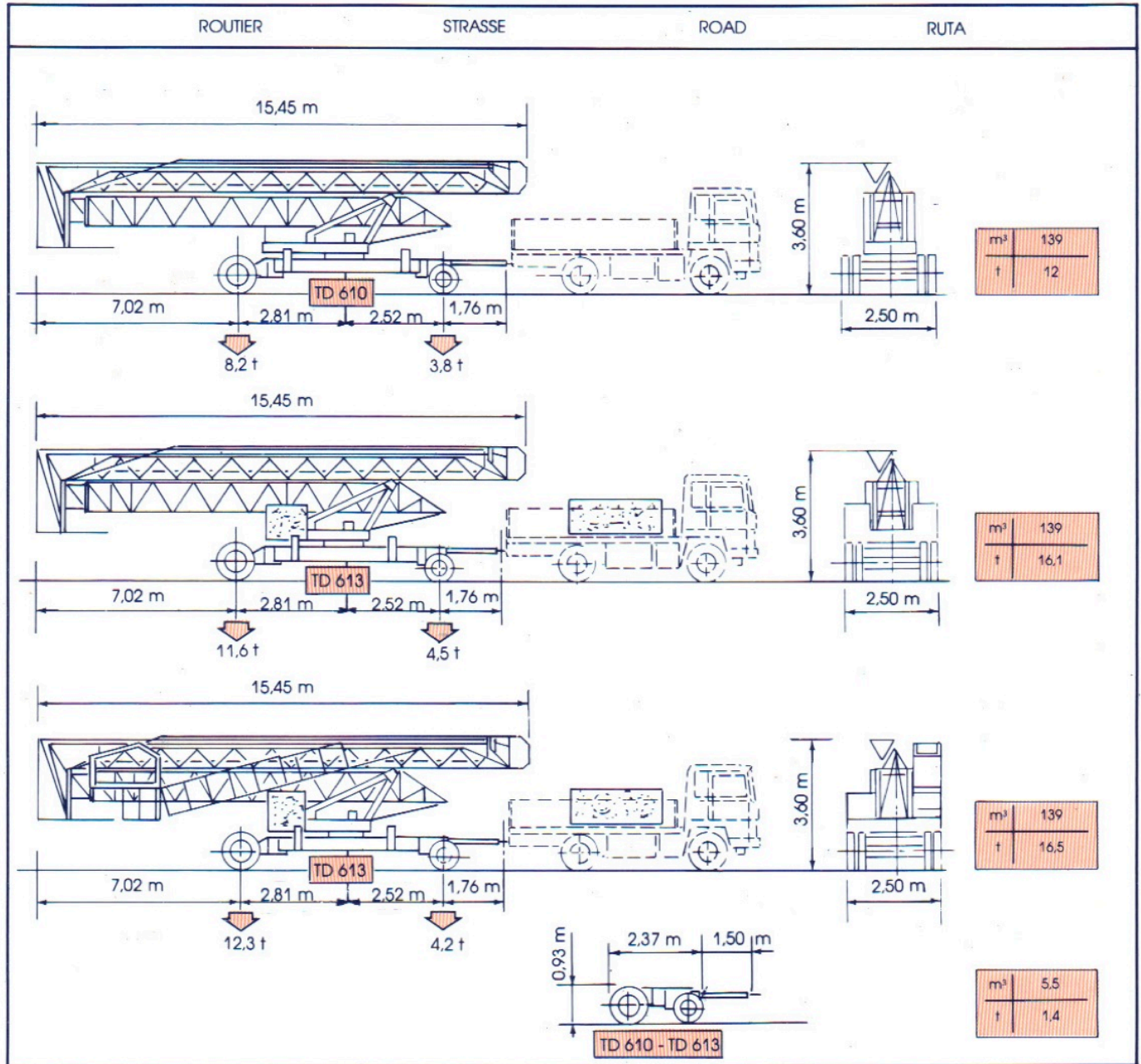

Transport

Transport

Transport

Transporte



CADILLON

CADILLON INDUSTRIE : 8, rue de Pretin - B.P. 25 - F 71120 CHAROLLES - FRANCE
Tél. 85 24 09 34 - Télex 800 418 - Télécopie 85 88 34 10

Filiale - Subsidiary - Filiale - Sucursal :

CADILLON BAUMASCHINEN G.m.b.h. : Am Dornbusch 4 - D 6108 WEITERSTADT
R.F.A. - Tél. 19 49 6151 85041 ou 85042 ou 85043
Télécopie 19 49 6151 82535 - Télex 041419223 +

CADILLON BAUMASCHINEN A.G. : Hofstr. 15 - CH - 8181 HORI
Tél. (19.41) 1.861.15.65 - Télécopie (19.41) 861.1250

CADILLON U.S.A. Inc. : 5777 West Century Boulevard - Suite 520 - LOS ANGELES
CALIFORNIE 90045 - Tél. 19.1.213.216.0060 - Télécopie 19.1.213.410.1017

BAUKRANE \$

STEINBERGER

☎ 08441 3479

www.steinberger-baukrane.de

THEIERE AL. DE J. BEAUBO 95 24 9
 G. ic BO "SAGE" N - Y. Jiffica ns ré véés Ander "gen" rbel" an - "jet y modif" tion" modif" tion" reser" das DA" N° 1.10.79