

BPR-Cadillon

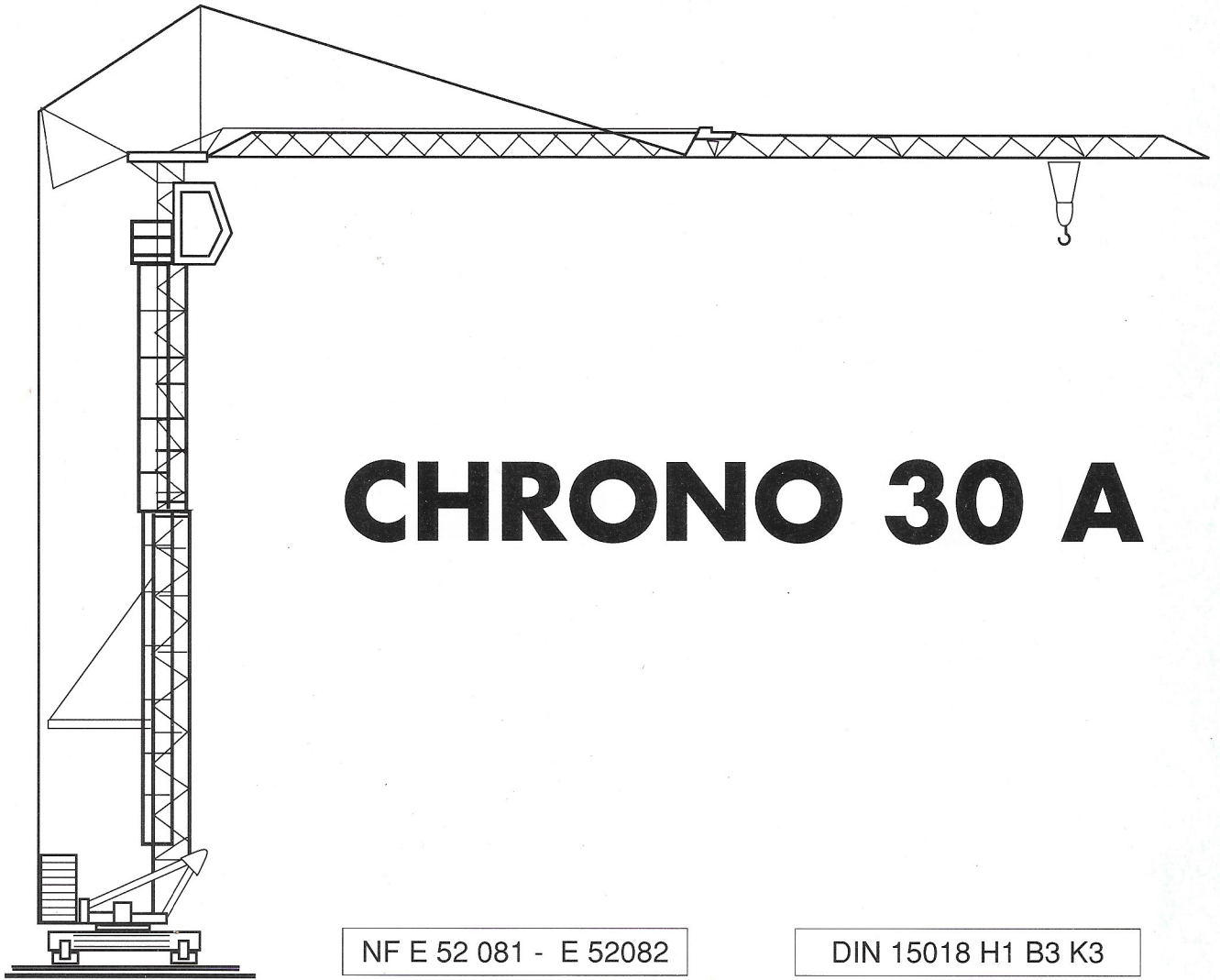

CHRONO 30 A

NF E 52 081 - E 52082

DIN 15018 H1 B3 K3

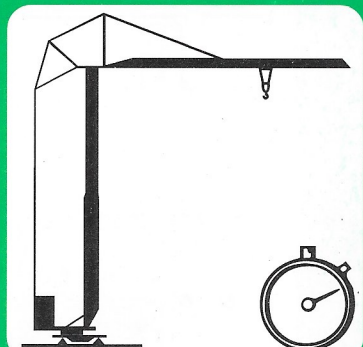
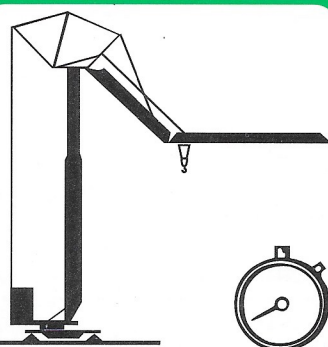
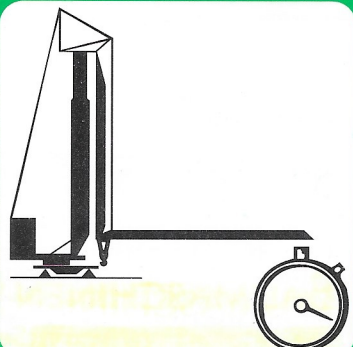

CHRONO 30 A

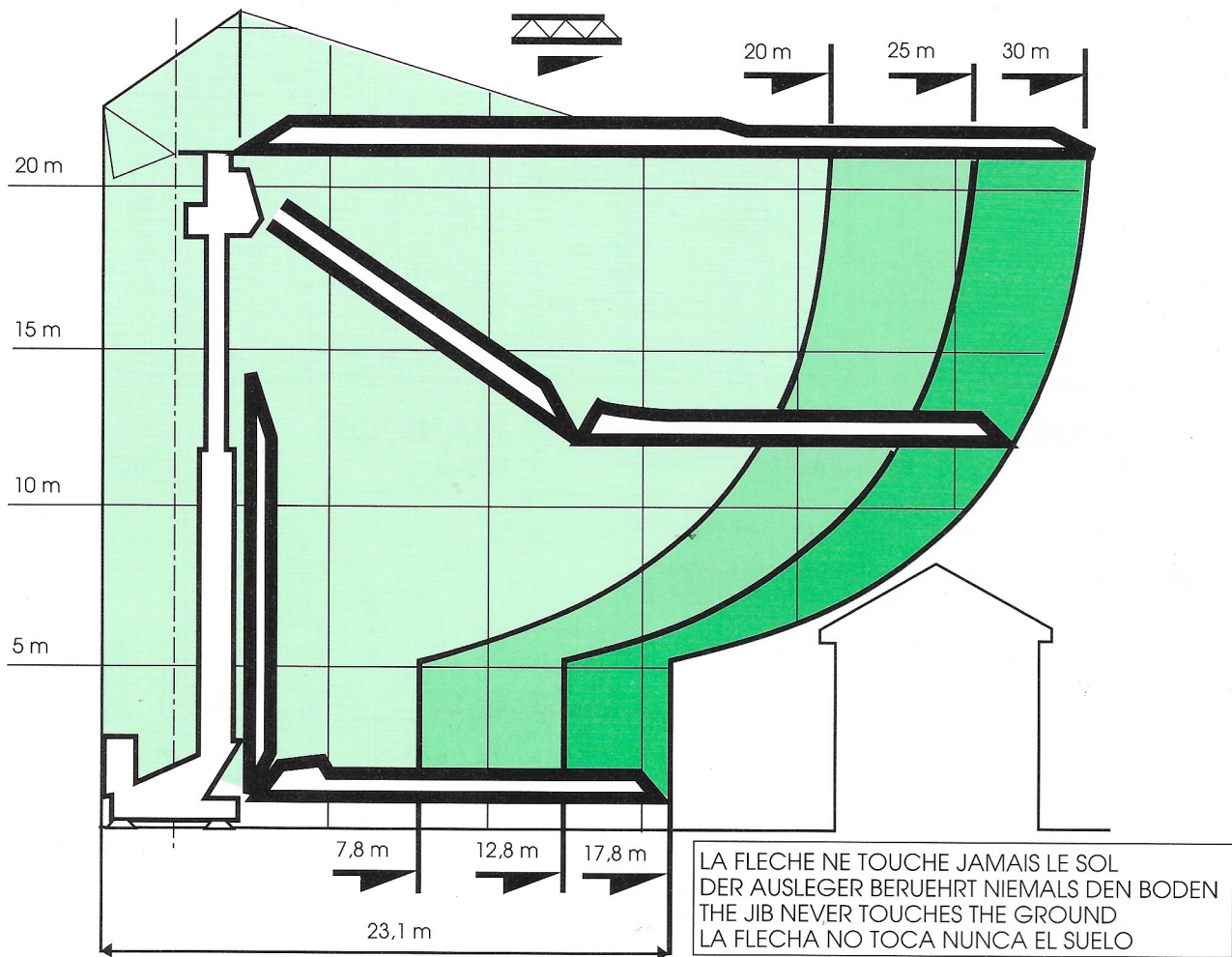

ENCOMBREMENT AU MONTAGE
SPACE REQUIREMENT

ABMESSUNGEN
ENCOMBRAMIENTO

GRUPE ELECTROGENE STROMAGGREGAT GENERATOR SET GRUPO ELECTROGENO
NOUS CONSULTER AUF ANFRAGE CONSULT US CONSULTARNOS

CHRONO 30 A		m/mn	KW	ch PS - HP	kg	⚡	
	I	3,8	2,2	3	3000	V	380 450
	II	18	11	15	3000	Hz	50 60
	III	36	11	15	1500	kVA	20 24
tr/mn U/mn Rpm V/mn		0,2 > > 1	2,2	3			
	I	17,5	1,1	3			
	II	35	2	3			
		0 > > 25	2 x 2,2	2 x 3			

Courbes de charges réduites de 20 % en flèche 30 m
Lastkurven vermindert um 20 % beim 30 m Ausleger
Load curves reduced of 20 % with 30 m jib
Curvas de cargas reducidas de 20 % en pluma de 30 m

CHRONO 30 A

VERSIONS SUR CHASSIS

UNTERWAGEN

UNDERCARRIAGE

CHASIS

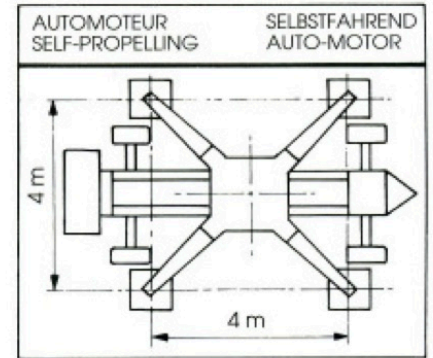
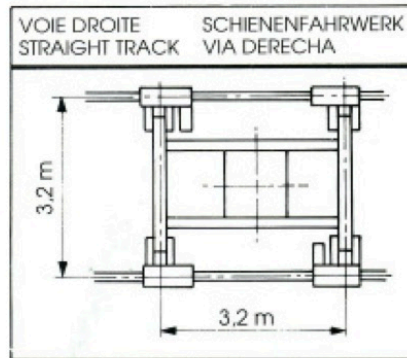
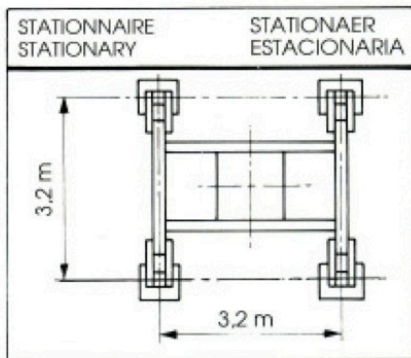

TRANSPORT
ROUTIER

TRANSPORT
STRASSE

TRANSPORT
ROAD

TRANSPORTE
RUTA

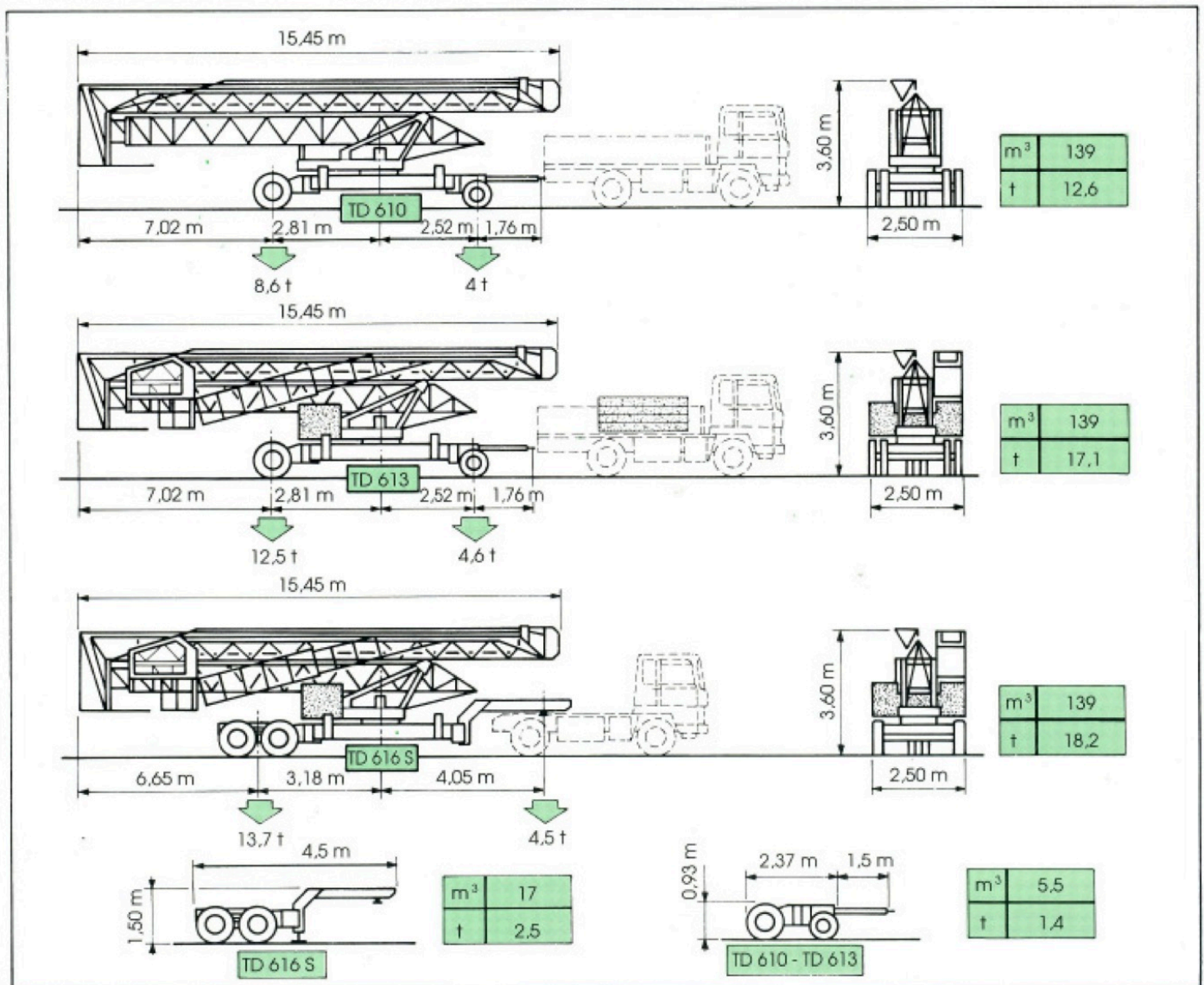

BPR-Cadillon
GROUPE LEGRIS INDUSTRIES

Siège social : 17, rue de Verdun - BP 25 - 71120 CHAROLLES - France
 Tél. : 85 24 09 34 - Télex : 800 418 - Fax : 85 88 34 10
 138, rue Julian Grimau - 94408 VITRY-SUR-SEINE Cedex - France
 Tél. : (1) 45 73 39 70 - Télex : 260 728 - Fax (1) 46 73 39 79
 11, rue de la Ligne de l'Est - BP 1064 - 69613 VILLEURBANNE Cedex
 Tél. : 72 34 99 00 - Télex : 370 242 - Fax : 72 34 99 20
 CADILLON BAUMASCHINEN G.m.b.H. : Am Dombusch 4 - D 6108 WEITERSTADT
 Tél. 0 6151 85041 ou 85042 ou 85043 - Télécopie 0 6151 82535 - Télex 041419223 +

DATA N° 283.13.0591

BAUKRANE STEINBERGER

BPR-Cadillon Service-Vermietung
 Vertrags-Händler
 Kreuzhof 1 • 85304 IImmunster
 Tel.08441/3479 • Fax 08441/76578
www.steinberger-baukrane.de